

ACC-IOX-RELAY Security Relay

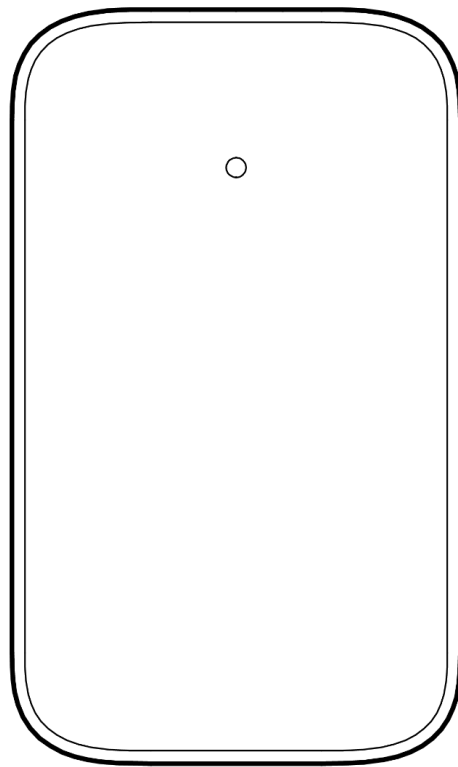

Document

Document Details

Version

v1.0 (20260417)

(V1.0 published 20260417)

Firmware

Firmware version can be verified on Verkada Command
command.verkada.com.

Product Models

This install guide pertains to model ACC-IOX-RELAY.

© Copyright 2025 Verkada Inc. All rights reserved.

Verkada and the Verkada logo are registered trademarks or service marks of Verkada Inc. (“Verkada”). All other trademarks are the property of their respective owners.

Verkada may make changes to this document at any time without notice. The information presented herein may be inaccurate or outdated, and Verkada is under no obligation to maintain it. ALL INFORMATION IS PROVIDED “AS-IS” AND WITHOUT ANY WARRANTIES, IMPLIED, EXPRESS, OR OTHERWISE. VERKADA DISCLAIMS LIABILITY FOR ALL DAMAGES, INCLUDING WITHOUT LIMITATION ANY DIRECT, INDIRECT, SPECIAL, INCIDENTAL, PUNITIVE, OR CONSEQUENTIAL DAMAGES, ARISING OUT OF USE OF THIS DOCUMENT.

Any intellectual property rights relating to Verkada products are and shall remain Verkada’s exclusive property. Use of any Verkada product is subject to Verkada’s end user agreement or other executed agreement with Verkada. No license, either expressed or implied, to use or distribute any Verkada product is granted under this document.

This document may not be sold, resold, licensed or sublicensed and may not be transferred without Verkada’s prior written consent. No part of this document may be reproduced in whole or in part without the express written consent of Verkada.



What's in the Box

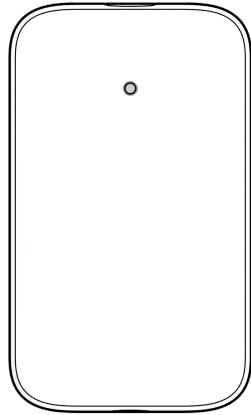

Security Relay



Mount Plate



**T10 Torx
Security L-Key**

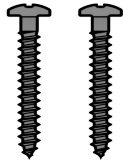

**M3.5 Wood Screws
(2 pcs)**

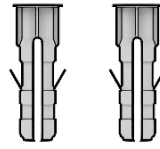

**Wall Anchors
(2 pcs)**



**Zip Tie for
strain relief**

What you'll need

- A smartphone or laptop
- #2 Phillips head and power drill (if using mount plate)
- 1/4 inch (6.5mm) drill bit for wall anchor pilot holes (if using mount plate)
- 1/8 inch (3.2mm) drill bit for wood screw pilot holes (if using mount plate)

Placement

Place the product on a wall or in a junction box.

Connect

For easy registration and setup, scan the QR code on the product.

If you prefer to manually register your product, please proceed to:

verkada.com/start

Overview

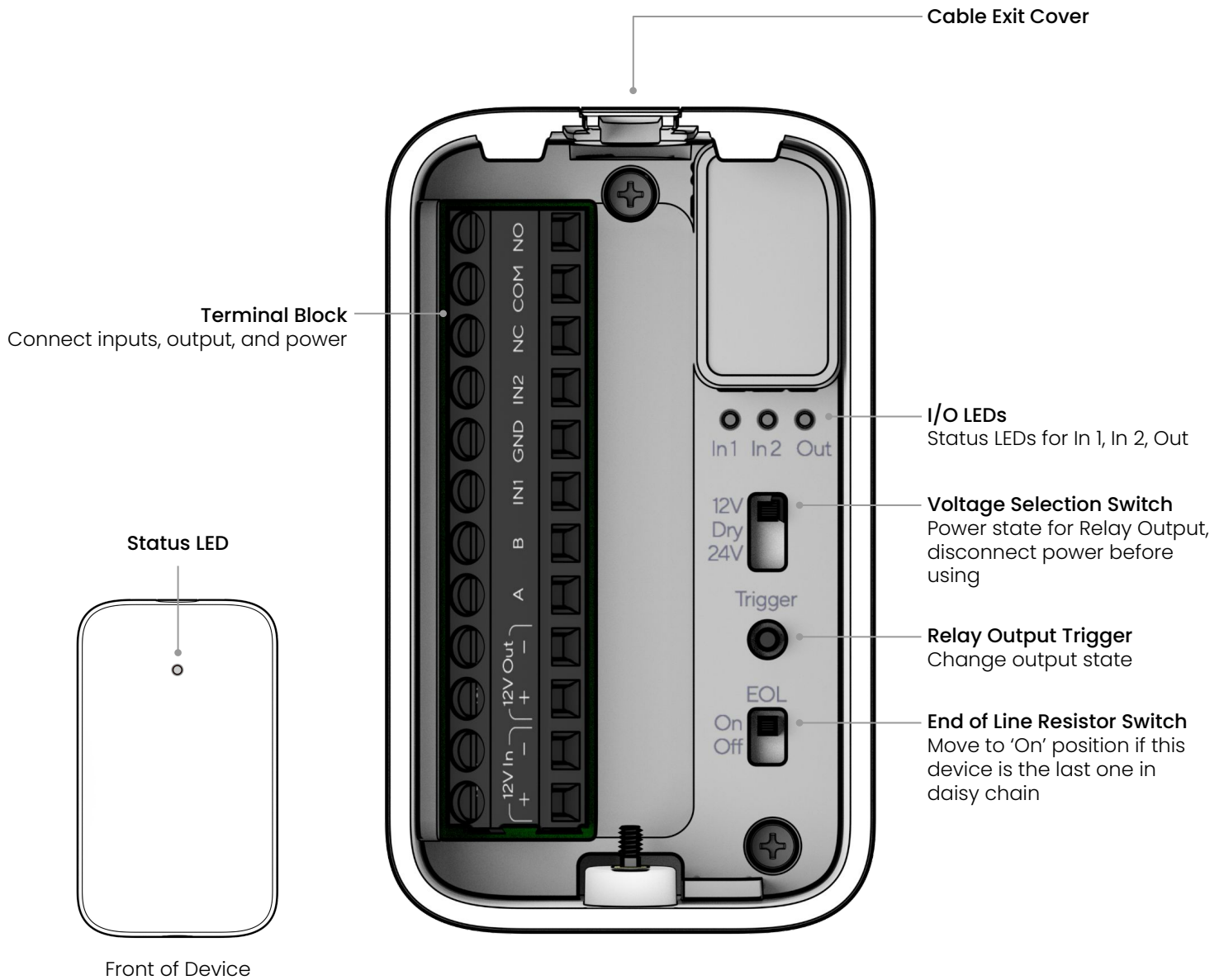

Status LED Behaviors

- **Solid Blue**
On & connected RS-485
- ☀ **Flashing Blue**
On & disconnected RS-485
- ☀ **Flashing Orange**
Updating firmware

I/O LED Behaviors

- ☀ ○ ○ In 1 triggered
- ☀ ○ In 2 triggered
- ○ ☀ Relay output triggered



Terminal Block

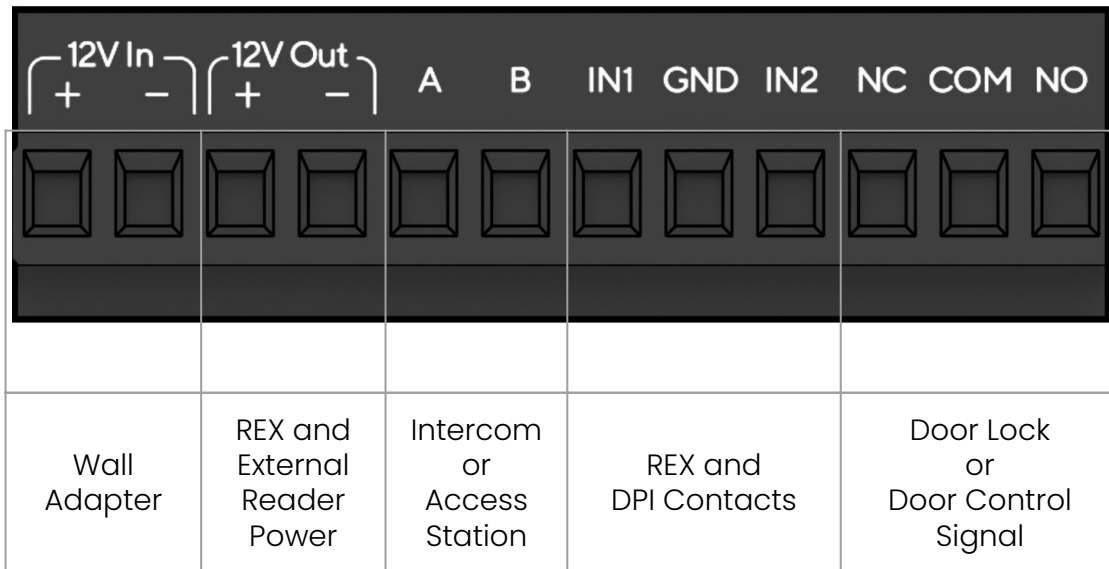

Recommended use: One twisted pair for GND and VIN (power) & one twisted pair for the data (D0/D1 or A/B). Wiring methods shall be in accordance with National Electrical Code, ANSI/NFPA 70.

Excess Wire Trimming

Avoid pinching cables during install as that may affect performance. If excess cables, trim to reduce slack.

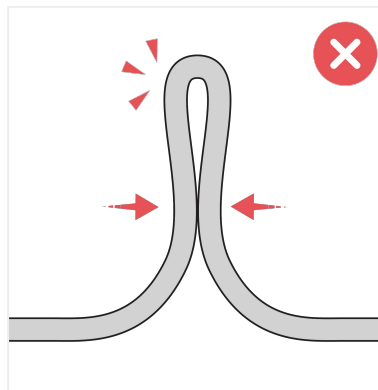

Avoid pinching the cable

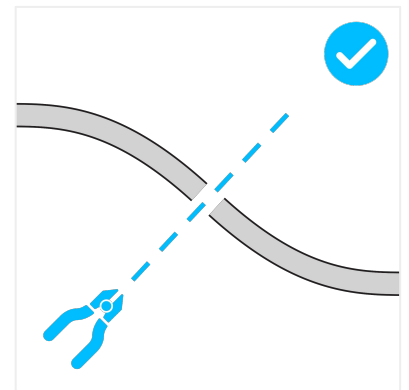

Trim excess cable

Technical Specifications

Power Input	20W maximum input
Voltage Input	12 VDC Input
IOs	<p>2x REX/DPI Dry Inputs 1x RS-485 In/Out 1x 12V Out @ 0.5A 1x wet relay for door with switch-selectable power:</p> <ul style="list-style-type: none"> • 12VDC operation @ 0.75A maximum • 24VDC operation @ 0.5A maximum • Dry operation, max pass-through current 1A @ 30VDC
Dimensions	47.4 x 79.8 x 30.9 mm (1.87 x 3.14 x 1.22 in)
Weight	84.1 g (0.19 lb)
Tamper Detection	Yes
Operating Temperature	-10 °C-50°C, 5-85% relative humidity
Compliance	<p>FCC Part 15B Class B, ICES-003 Class B, CE, UKCA, VCCI, RCM, UL 294, CAN-ULC 60839-11-1, IK07, Indoor Use Only, to be used in controlled, protected, and/or restricted access areas.</p> <p>Installation and operation of the electronic access control system (EACS) shall not prevent the functionality of the emergency exit functions.</p>
Mounting Options	Wall, ceiling, or junction box
Included Accessories	T10 security Torx hex key, mounting hardware kit, strain relief zip tie

Installation

Placement Options

Note: Install the Security Relay on the *secure side* of the door to avoid tampering and compromised security of this device.

The Security Relay can be mounted on a wall, with the Mount Plate, or placed inside a junction box.

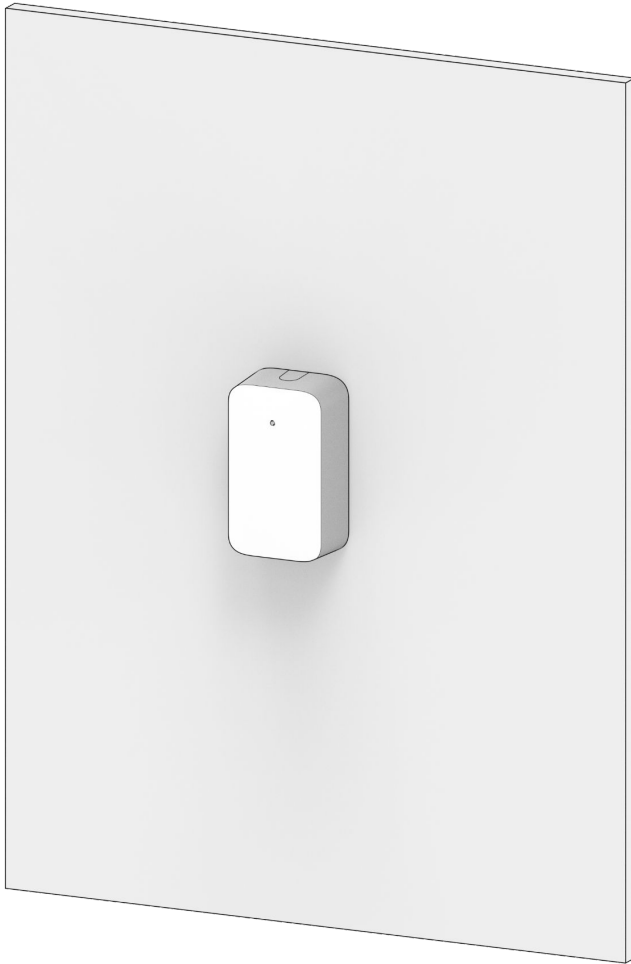

Mounting on wall



Placing inside a junction box

Installation

Mounting

Mounting to Wall

Cable routing options: The cable can be passed through the wall or the cable exit.

Use the Mount Plate as a template to mark holes for mounting and cable pass-through, if needed.

Secure the Mount Plate using the screws and wall anchors.

Refer to the *Wiring Instruction* section of this document.

After completing the wiring, engage the hook and swing the device toward the mount plate.

Tighten the security screw to lock the Security Relay in place.

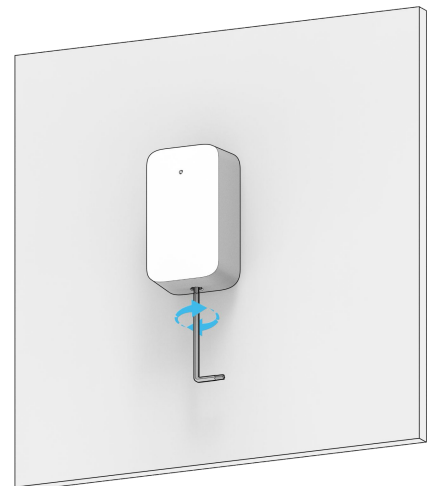
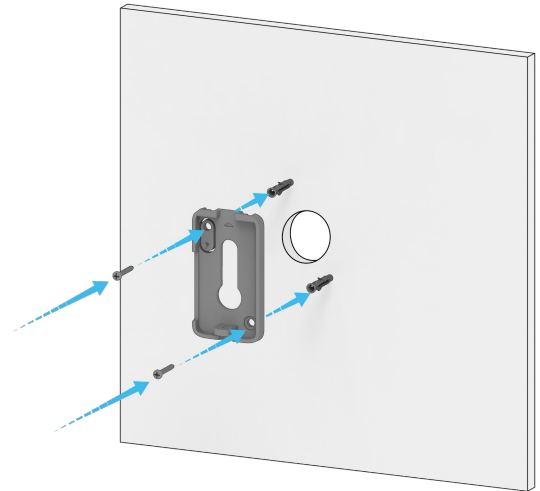

Installation

Mounting

Placing inside a junction box

Pass the wire through the junction box conduit hole.

Refer to the *Wiring Instruction* section of this document.



Installation

Wiring Instruction

Connect Power

Use ACC-WA-30W/12V or another 30W 12V DC power supply. For UL294 installations, you will need a UL294 Listed 12VDC external power supply.

Connect Intercom or Access Station

ACC-IOX-RELAY is designed to communicate with a Verkada Intercom or Access Station over the RS-485 connection.

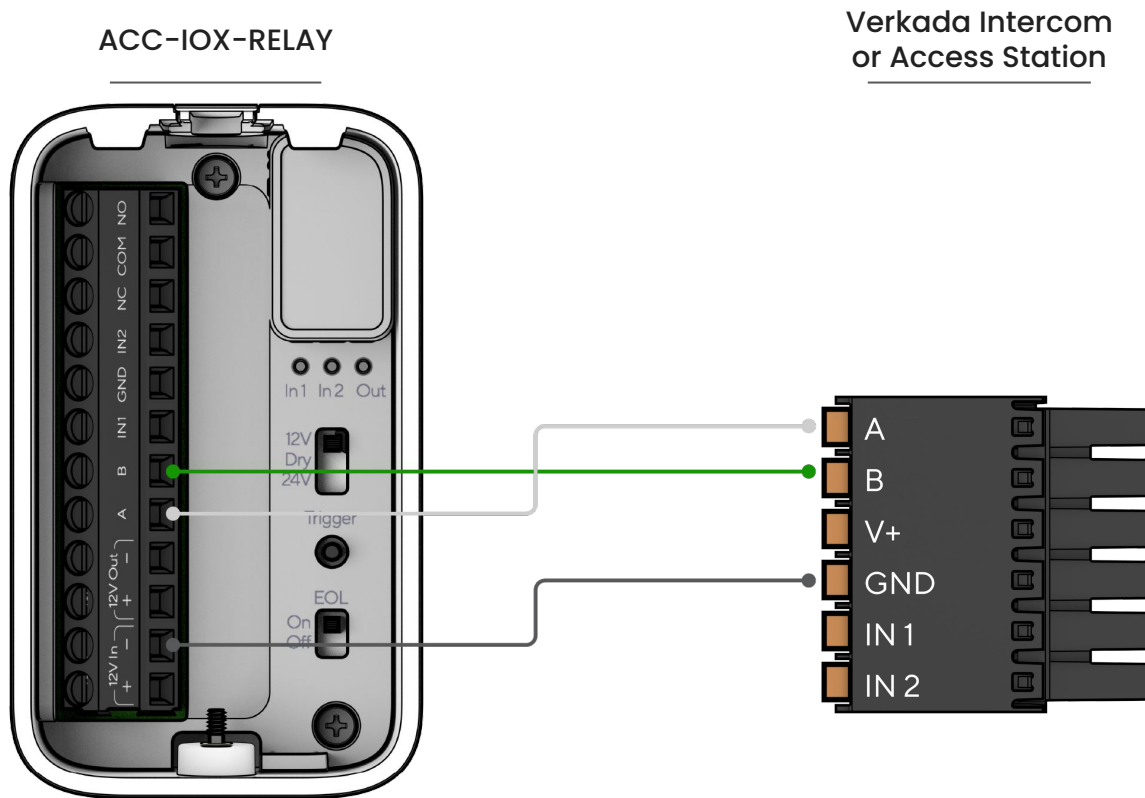

Note: Cables are recommended to be shielded.

WHITE = A
GREEN = B

Wiring Instruction

Connect the Lock (Dry)

When using an external power supply which accepts a dry contact, ensure that "Dry" is selected on the door power selection switch.

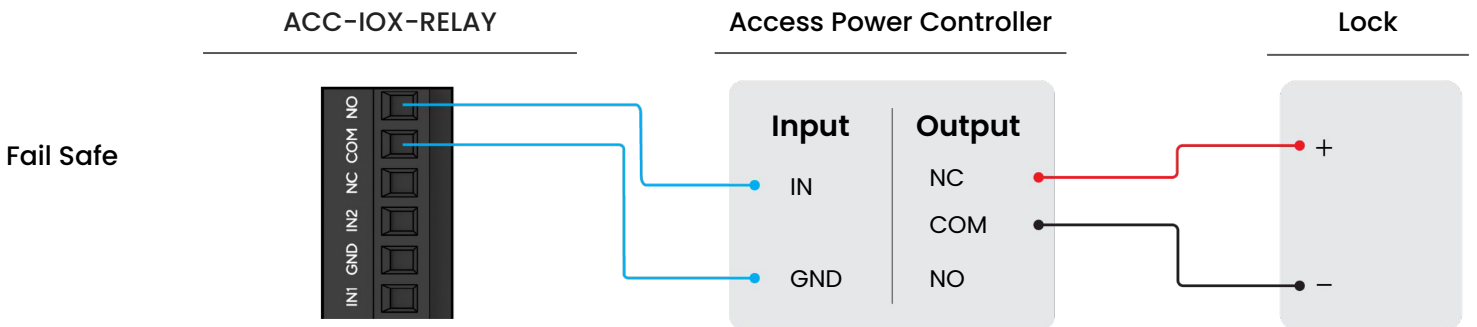
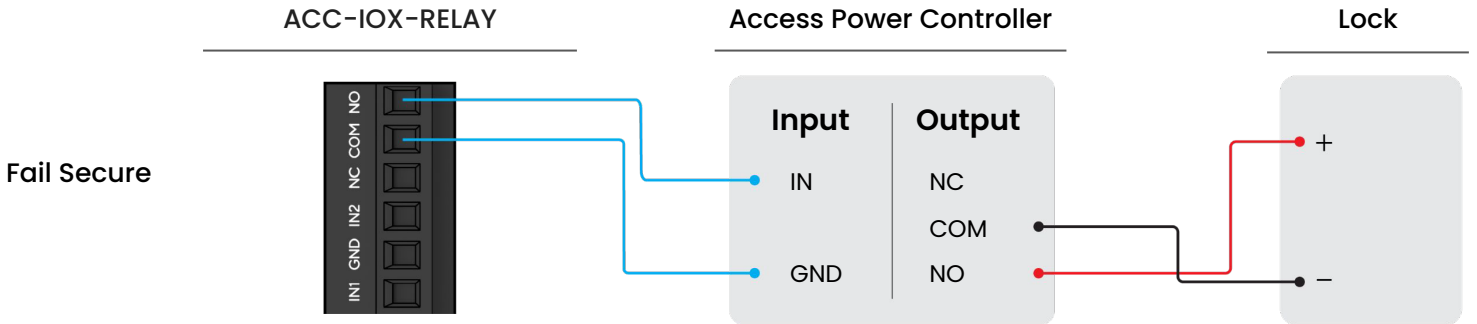

Connect the Lock (Wet)

In a Wet configuration, ensure that power selection switch is set to the correct voltage as outlined by the locking hardware specifications.

- Set it to "12VDC" for 12 volt locking hardware
- Set it to "24VDC" for 24 volt locking hardware

The ACC-IOX-RELAY is rated to power:

12V locks up to 700mA and 24V locks up to 320mA.

Warning

When connecting the lock in the Wet configuration, ensure the negative of the lock goes into the COM port as shown in the diagrams below.

Fail Secure

LOCK (+) positive goes into NO
 LOCK (-) negative and ground wire goes into COM

Fail Safe

LOCK (+) positive goes into NC
 LOCK (-) negative and ground wire goes into COM

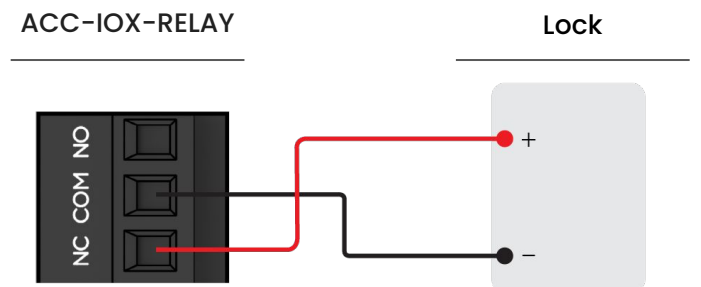
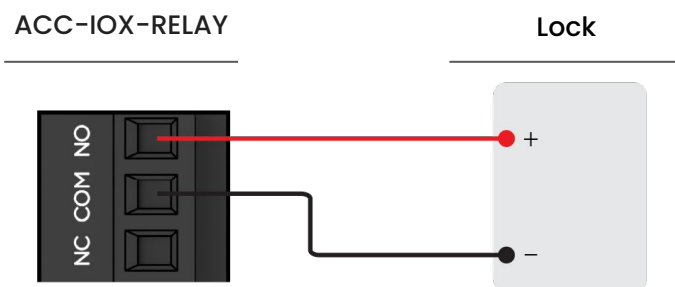

Wiring Instruction

Connect the Inputs

Both the Door Position Indicator (DPI) and the Request-to-Exit (REX) inputs are dry contacts. Installing these inputs is optional. They can be configured in Verkada Command.

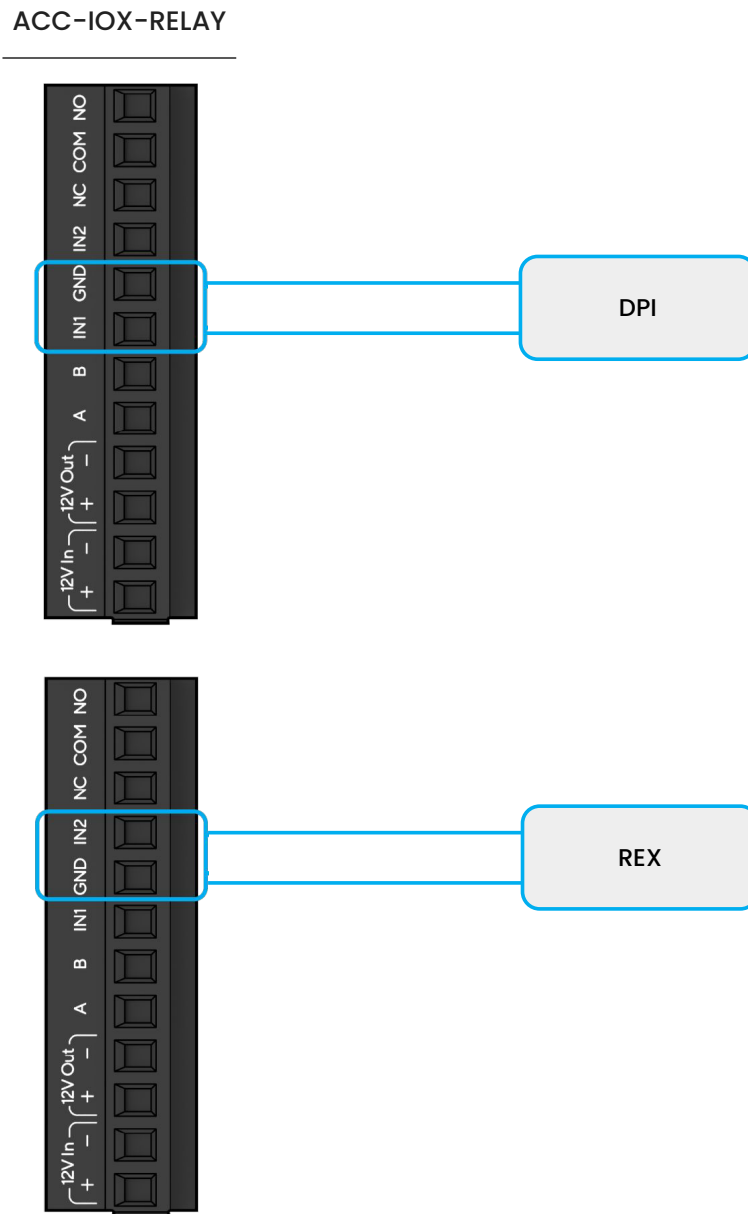

The REX can be configured in Verkada Command to release the lock; this is most commonly seen in electromagnetic locks. The REX unlock time and normal state can be configured.

Important

When configuring the Intercom or Access Station as a single door controller, the DPI should be connected to IN 1, while the REX should be connected to IN 2.



Appendix

Compliance

FCC Compliance

This device complies with part 15 of the FCC Rules. Operation is subject to the following two conditions: (1) This device may not cause harmful interference, and (2) this device must accept any interference received, including interference that may cause undesired operation.

NOTE: This equipment has been tested and found to comply with the limits for a Class A digital device, pursuant to part 15 of the FCC Rules. These limits are designed to provide reasonable protection against harmful interference when the equipment is operated in a commercial environment. This equipment generates, uses, and can radiate radio frequency energy and, if not installed and used in accordance with the instruction manual, may cause harmful interference to radio communications. Operation of this equipment in a residential area is likely to cause harmful interference in which case the user will be required to correct the interference at his own expense.



Appendix
Support

Thank you for purchasing this Verkada product. If for any reason you're experiencing issues or need assistance, please contact our 24/7 Technical Support Team immediately.

Sincerely,
The Verkada Team
verkada.com/support

